

C-Series OTC25 Digital Temperature Controller



- ▲ Accepts Type J (OTC25-N & L) or Type J and K (OTC25-P) Thermocouple Input
- ▲ Adjustable Output Hysteresis to Prevent Rapid Cycling Around Setpoint Temperature
- ▲ Adjustable Deviation Alarm Flashes When Measured Temperature Exceeds or Falls Below Setpoint Temperature
- ▲ NEMA 4X (IP65) Front Bezel, Splash-Proof and Resistant to Dust
- ▲ Discrete Status Indicators Illuminate When Temperature Display, Setpoint Display, Limit Display, or Heat/Cool Output is Active
- ▲ RU, cRU, CE, and FM Approvals

The Athena OTC25 is a 1/4 DIN panel mounted, digital controller that can be used for precise control of a single loop with two independent outputs. The controller accepts thermocouple input, and a large easy-to-read digital LED display is selectable for either setpoint or process temperature.



Ordering Information

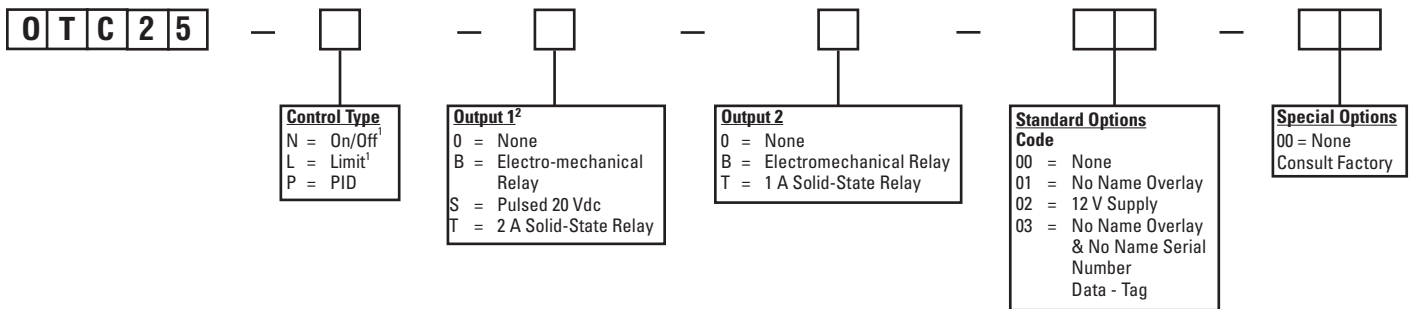

¹ On/Off and limit control versions (OTC25-N and OTC25-L) are only available with Type J thermocouple input.

² Limit control versions (OTC25-L) may only be ordered with electromechanical relay (Type "B") outputs in Output 1.

Technical Specifications

Operating Limits

Ambient Temperature	32°F to 140°F (0°C to 60°C)
Relative Humidity Tolerance	90% R.H. maximum, non-condensing
Line Voltage	100 to 250 Vac 50/60 Hz
Power Consumption	Less than 6 VA (instrument)

Performance

Accuracy	±0.3% of FS, ± one digit
Temperature Stability	5 µV/°C maximum
TC Cold End Tracking	0.05°C/°C ambient
Noise Rejection	Common mode > 100 dB Series mode > 70 dB
Process Sampling	3.7 Hz (270 ms)

Control Characteristics

Setpoint Limits	0°F to 900°F (0°C to 482°C)
Control Hysteresis	2°F to 252°F (1°C to 140°C)
Display Offset	-126°F to +126°F (-70°C to 70°C)
Deviation Alarm	Off, 1°F to 252°F (Off, 1°C to 140°C)

Inputs

Thermocouple	OTC25-N	Type J
	OTC25-L	Type J
	OTC25-P	Type J or K
Maximum lead resistance, 100 ohms for rated accuracy		

Outputs

B	5 A @ 120 Vac, 3 A @ 240 Vac electromechanical relay
T	Solid-state relay, 2 A (Output 1), 1 A (Output 2)
S	Pulsed 20 Vdc

Mechanical Characteristics

Display	3-digit, 0.56" (14.2 mm) Orange
Discrete Indicators	Setpoint: Amber Actual: Amber O1: Orange O2: Orange Limit: Orange
Front Panel Rating	NEMA 4X (IP65)
Connections	Fast-on style
Front Panel Cutout	3.622" x 3.622" (92 mm x 92 mm)

Specifications subject to change without notice.

Panel Cutout: 3.622" sq. (92 mm)

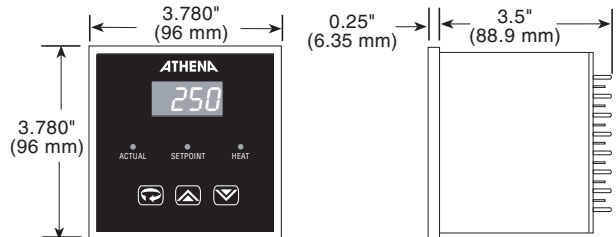

Front Panel Controls and Indicators

