



SERIES 18C/19C/25C

TEMPERATURE/
PROCESS
CONTROLLER

*Standard Options
and Digital
Communications
Users Guide*



Table of Contents

For information and instructions related to basic operations, refer to the Series C operator's manual supplied with your controller.

Option Wiring Diagrams

Alarm Output	4
24 Volt DC Alarm Output	4
Relay, N.O. Alarm Output	5
RS-232 Communications	5
RS-485 Communications	6
Transducer Excitation	6
Auxiliary Output	7
Remote Analog Setpoint	7

Guide to Digital Communications

Remote Communications Options	8
Athena+ Protocol	8
- Message Formats	9
- Sample Commands	10
- Request Messages	13
- Response Messages	14
- Communications Parameter List	16
- Auxiliary Commands	26

Alarm Outputs

Option T: Alarm Output, N.O.

This optional hardware module provides alarm drive outputs. LED indicators A1 and A2 are used to indicate alarm conditions as configured in the Alarm Menu.

Load Limits:

Max. Load Current—1 A rms

Min. Load Current—0.5 mA rms

Power Factor Range—0.2 to 1.0

(can drive small motors, solenoids, valves, and contactors)

Max. Surge Current Non-repeating

for 1 second— 7.5 A

Max. I²T for fusing (0.01 sec)—4.5 amp-squared seconds (1A - ABC1 typical fuse)

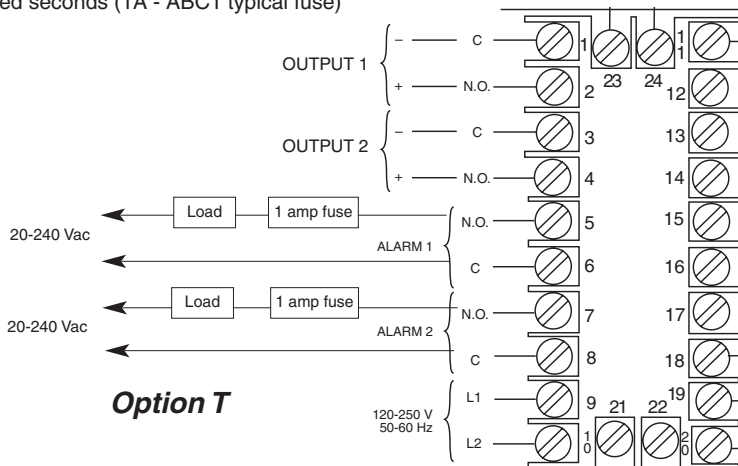

Option T

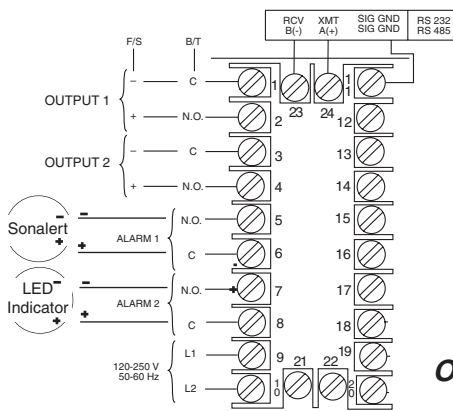

Option S

24 Vdc

Alarm Output

Option S: 24 Vdc Alarm Output

Option Description: 24 V output with clamping diodes Source current is limited to 25 mA (1000 ohm resistor) Open circuit voltage is 25 volts

Isolation: Isolation 300 volts ac/dc either output to instrument

Relay, N.O. Alarm Output

Option B: Relay, N.O. Alarm Output

Option Description: NO (Normally open) relay contact is closed when either alarm is active.

The relay life is greater than 100,000 operations at 5 operations per second switching full load.

*Connect load and supply voltage per the following table:

Load Type	5 A Voltage Limit
Resistive DC	30 Vdc
Inductive DC (L/R = 7 ms)	20 Vdc
Tungsten Lamp, 360 W	120 Vac
Resistive AC	250 Vac
Inductive AC (pF = 0.4)	150 Vac
Motor, AC, 1/6 hp	250 Vac

RS-232 Communications

Option A: RS-232 (one-to-one) Communications

Option Description: Provides a one-to-one connection between the controller and an RS-232 port. Computers, PLCs, or dumb terminals may be used to set and access controller data.

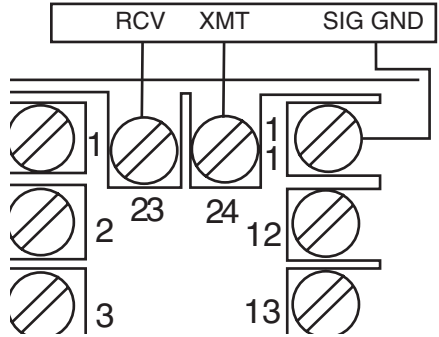
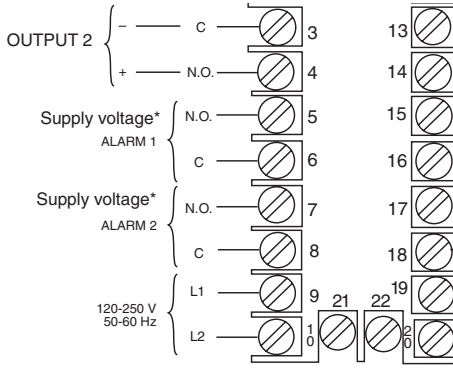

RS-485 Communications

Options B&C: RS-485 (one-to-many) Communications

Option Description: Provides one-to-many communications.

Terminate the controller furthest from the computer by either connecting a 120-ohm, 1/4-watt resistor between terminals 23 and 24.*

*Terminate only if the total distance from controller to computer exceeds 2000 ft. Termination is to minimize signal reflections or "echoes" on the line.

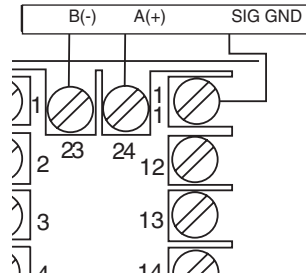

Transducer Excitation

Options 1, 2, 3, and 4: Transducer Excitation

Option Description: The transducer excitation option provides power to remote transducers. The transducer outputs, in turn, provide a signal to the controller input which can be scaled in the appropriate engineering units.

All options will provide at least 20 mA. The transducer circuitry is thermally protected from short circuits.

- Option 1: 10 Vdc**
- Option 2: 12 Vdc**
- Option 3: 15 Vdc**
- Option 4: 5 Vdc**

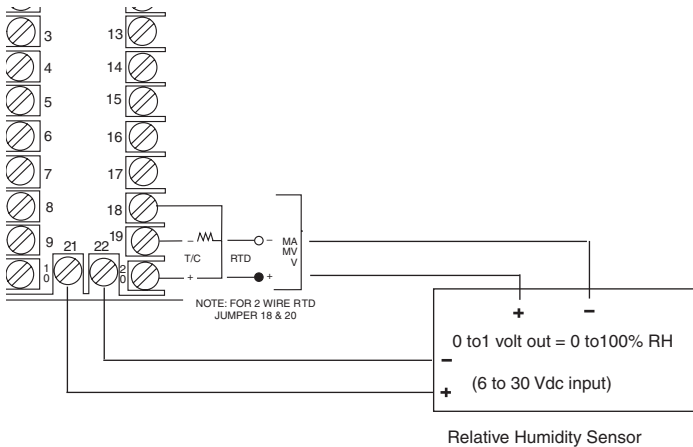

Auxiliary Output

Option PA, PB, PC, and PD: Auxiliary Output

Option Description: The Setpoint Variable or Process Variable is transmitted to a remote device (chart recorders, indicators, data recorders, computers, process controllers, etc.) with 1 of 4 different interfaces:

Option PA: 4-20 mA

Option PB: 1-5 V

Option PC: 0-20 mA

Option PD: 0-5 V

The output signal is scalable in the Auxiliary Output Menu. Multiple remote indicators may be driven by the controller. For current (mA) options, the remote indicators are connected in series. The sum of the input resistance for all remote indicators must be less than 400 ohms. For voltage options, the remote indicators are connected in parallel.

The sum of the currents for all remote indicators must be less than 10 mA.

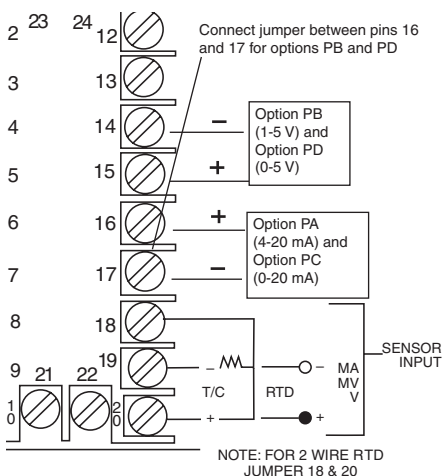

Remote Analog Setpoint

Option SA, SB, SC, SD, SE, and SF: Remote Analog Setpoint

Option Description: Remote setpoints use either voltage or current inputs, depending on the specified option:

Option SA: 0-5 Vdc

Option SB: 1-5 Vdc

Option SC: 0-20 mA

Option SD: 4-20 mA

Option SE: Switch Input Only

Option SF: 0-10 Vdc

The input signal is scalable in the Remote Analog Setpoint Menu. Activation of the analog setpoint causes the F1 indicator to illuminate. For current (mA) options, the input resistance is 255 ohms. For voltage input options, the input resistance is greater than 10K ohms. Note: Switch input option SE is only active when switch is closed. The digital input option **cln** menu controls the programming of this switch.

Options SA, SB, SC, SD, SF

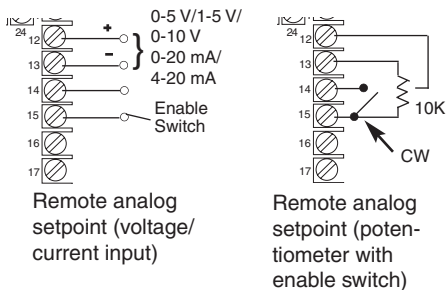

Option SE

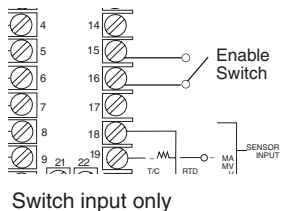

*Ground shield at one end, taking care not to run wires next to power circuitry. Maximum length will be determined by noise performance.

Digital Communications Option

Three remote communications options are available for the 18C/19C/25C which allow interfacing to remote devices utilizing the most common industry standards: RS-232, RS-422, and RS-485

Remote Communications Options

RS-232

This method allows bidirectional data transfer via a three-conductor cable consisting of signal ground, receive input and transmit output. It is recommended for communication distances less than 50 feet between the computer terminal and the instrument. Note: Multiple instruments cannot be connected to the same port.

The RS-232 port is optically isolated to eliminate ground loop problems. Typically, "Data Out" of the computer/terminal connects to the "RCV" terminal. "Data In" connects to the "XMT" terminal. If shielded cable is used, it should be connected to the frame ground at one end only. Signal ground is to be connected at appropriate ground terminals (refer to wiring diagram on next page).

RS-422

This method allows bidirectional data transfer via a four-wire conductor cable for distances over 4000 feet between the computer terminal and the instrument. A signal ground wire is not required.

RS-485

The RS-485 multipoint capability allows up to 32 controllers to be connected together in a half-duplex network or up to 100 controllers with an appropriate communications repeater.

This method allows bidirectional data transfer over a twisted pair cable. The twisted pair cable is a transmission line; therefore, terminating resistors are required at the most distant ends of the line to minimize reflections (typically 120 ohms at each end). The RS-485 circuit is fully optically isolated, eliminating ground loop problems. Parallel drops from the transmission lines should be kept as short as possible; however, the line may be daisy-chained at each controller. The polarity of the line is important and each device will specify an "A" (+) and "B" (-) connection.

Note: Call factory for a recommended RS-485 converter.

Figure 1. Wiring diagram for digital communications.

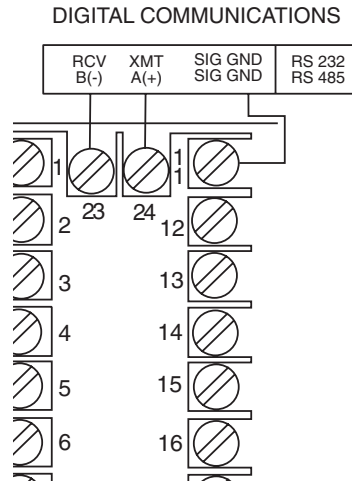

Athena+ Protocol

The Athena+ Protocol provides an easy way to query and modify controller parameters using a personal computer and the optional digital communications option of the 18C/19C/25C.

In this manual, the word "host" refers to the personal computer that's communicating with the controllers in the serial link, and the word "slave" refers to the controllers themselves.

All transactions between the host and the slaves are done with messages consisting of only printable ASCII characters.

There are only two primary types of messages: Requests and Responses. Messages coming from the host are called requests and messages coming from the slaves are called responses.

With the exception of a broadcast request, for every request sent from the host, the slave will send back a response. If a slave does not respond within 100 milliseconds, then the request can be considered lost.

A broadcast request is a request having an ID of '00' (see Message Formats on next page). It is used to address all slaves on the network. All slaves on the network will perform the actions requested in a broadcast message. However, a response message will not be returned. Therefore, the host can only broadcast Write or Auxiliary Command Requests. All slaves will ignore all Read Broadcast Requests.

Message Formats

All Athena+ messages adhere to the general format of:

```
[STARTCHAR][ID][ZONE][TYPE][PARAM]
[ERROR][DATA][CHKSUM][END CHAR]
```

START CHAR

This is a single character which designates the start of the message. For a Request message, this character is the ASCII '\$' and for a Response message, this character is the ASCII '%'.

ID

This is a two-character ID identifying the receiving controller. Controller IDs go from 1-255 inclusively and all slaves in the network must have unique IDs. The ID number of '00', when used in a request, designates a broadcast message that is used to address all controllers in the network. See the section Request Message for an explanation of the broadcast message.

In order to represent 255 with just two ASCII characters, a number system known as the Message Code Numbering System is used. In this system, the most significant digit is represented with the numbers 0-9 and the letters A-Z and the

least significant digit is represented with the numbers 0-9. The numbers 0-9 have the same values as their decimal counterparts and the letters A-Z have the values of 100 - 350 inclusively in increments of 10.

Example:

Message Code Value	=	Decimal Value
00		0 + 0 = 00
99		90 + 9 = 99
A0		100 + 0 = 100
A2		100 + 2 = 102
B8		110 + 8 = 118
P5		250 + 5 = 255

Zone

This is a two-character ID identifying the Zone number in multi-zone capable controllers. For the 18C/19C/25C, this number must be 01.

Type

This is a single character identifying the type of message. The following table lists the type characters for all messages.

TYPE Character	Message Type
R	Read Request or Read Response Returning a Positive Result
r	Read Response Returning a Negative Result
W	Write Positive Value Request and Response
w	Write Negative Value Request and Response
A	Auxiliary Command

For further information, see following sections on the different message types.

PARAM

This is a two-character, message specific, parameter ID. For a Read/ Write Request or Response message, this ID identifies the controller parameter. For an Auxiliary Command Request or Response message, this ID specifies the command.

ERROR

Code	Description
0	No error.
1	Framing error.
2	Hardware error.
3	Parity error.
4	Bad character in the TYPE field.
5	Bad message. Message cannot be understood.
6	Bad checksum. The checksum received did not match the checksum of the message.
7	Bad zone ID.
8	Bad auxiliary command ID. The auxiliary command is not supported in this controller.
9	Bad parameter ID. The parameter is not supported in this controller.
A	Bad data. Bad representation in the data field or data is out of range.
B	Attempt to write to a read only parameter.
C	Cannot write to a parameter because it's in use.

Examples of valid numeric representations for a 6 character data field (dot is considered a character):

Numeric Value	ASCII Representation
3	3.0000 000003 003.00
100	100.00 0100.0 000100
3.2	003.20 0003.2

Examples of invalid numeric representations for 6 character data field: (B represents a blank, or a space, character)

Numeric Value	Bad ASCII Representation	Why?
3	BBBBB3	Leading blanks are not allowed.
3.0	BBBB	Trailing blanks are not allowed.
-3.2	-3.20000	'.' is not allowed.

CHKSUM

This is a two-character Message Code Numbering System, representing the sum of all the ASCII values of all the characters (excluding the START, CHAR, the END CHAR, and the CHKSM themselves) in the message. The sum is computed using the following formula:

$$\text{CHKSM} = \text{SUM}(\text{All Message Characters}) \% 256$$

% represents the modulus operator.

END CHAR

This is a single character designating the end of the message. For all messages, the character used is <CR>, the carriage return.

READ COMMAND TO CONTROLLER

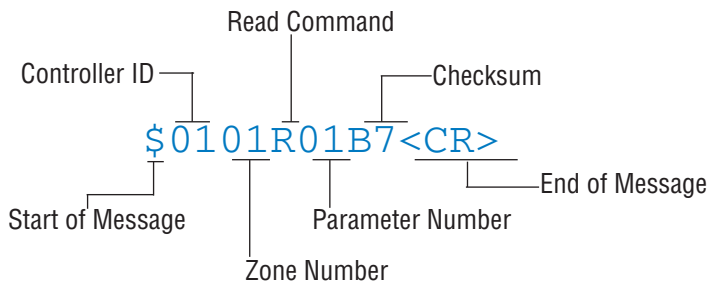

READ RESPONSE FROM CONTROLLER

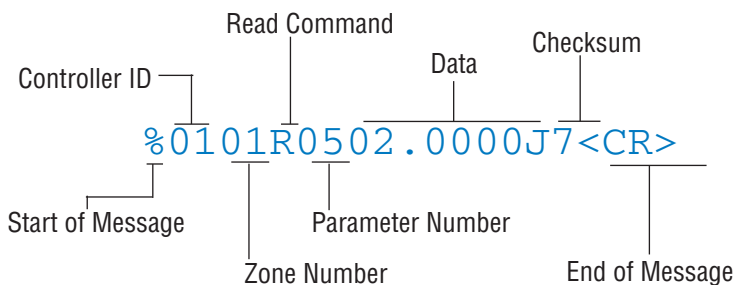

WRITE COMMAND TO CONTROLLER

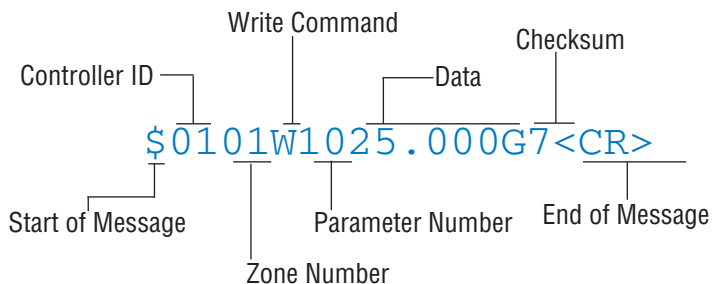

WRITE RESPONSE FROM CONTROLLER

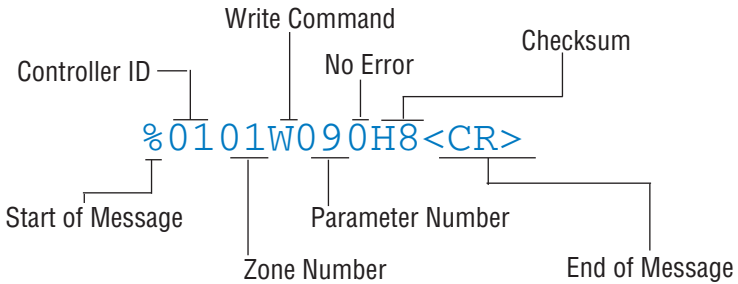

AUXILIARY COMMAND TO CONTROLLER

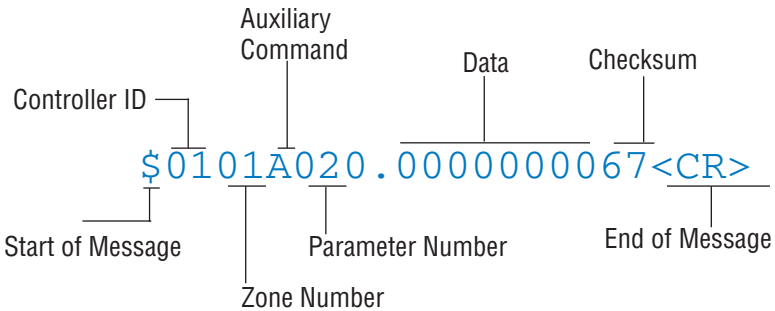

AUXILIARY RESPONSE FROM CONTROLLER

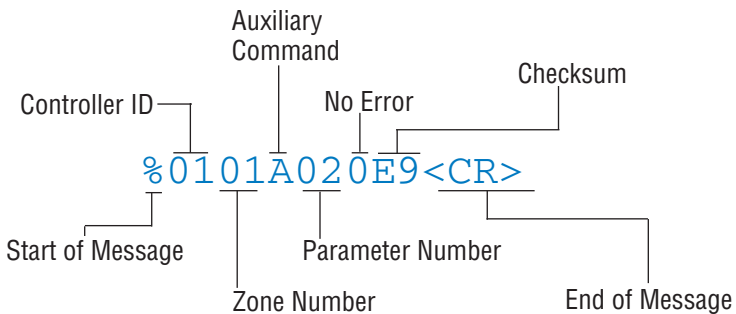

Request Messages

Request Messages are sent from the host to the slaves. Each request will have an ID identifying the intended recipient of the request. If the ID is '00' (zero), then the request is a broadcast message.

All slaves will perform the action requested in the broadcast request. However, a response message will not be returned. Therefore, it only makes sense to send Write or Auxiliary Command Requests as broadcast requests.

There are three types of Request Messages: Read, Write, and Auxiliary Commands.

The Read Request:

The Read Request is used to query parameter values and it has the following message format:

[STARTCHAR][ID][ZONE][TYPE][PARAM][CHKSUM][END CHAR]

Field Description:

TYPE Must contain the uppercase letter 'R'.

Request Message	Description
\$0101R05C1<CR>	Queries the value of the Process Variable of Controller #1.
\$0101R09C5<CR>	Queries the value of the EEPROM Setpoint 1 of Controller #1
\$0201R09C6<CR>	Queries the value of the EEPROM Setpoint 1 of Controller #2.

The Write Request:

The Write Request is used to modify parameter values and it has the following message format: [START CHAR][ID][ZONE][TYPE][PARAM][DATA][CHKSUM][END CHAR]

Field Description:

TYPE—This field must contain one of the following two characters.

W—Value in DATA is a positive value.

w—Value in DATA is a negative value.

DATA—A six-character ASCII representation of a numeric value.

Request Message	Description
\$0101W0910.123G7<CR>	Change both the RAM and EEPROM copies of Setpoint #1 in controller #1 to the value of 10.123
\$0101w1010.123J1 <CR>	Change only the RAM copy of setpoint #1 in controller #1 to the value of - 10.123 (notice the lowercase 'w').

Examples of the responses to these requests are given in later sections on **Response Messages**.

The Read Response:

The Read Response will be sent in response to a Read Request. Some examples:

Request Message	Description
%0101R05021.123K8<CR>	The value of the Process Variable is 21.123°C.
%0201R101G7<CR>	A serial transmission has occurred: Framing Error
%0101r09021.000N8<CR>	The value of the EEPROM setpoint #1 is -21°C (notice the lowercase 'r').

The Auxiliary Command Response:

The Auxiliary Command Response will be sent in response to an Auxiliary Command Request.

Some examples are:

Request Message	Description
%0101A010XXXXXXXXXX04<CR>	Default load all parameters has started.
%0201A0200.00000000B6<CR>	RTD low calibration on controller #2 has started.

The Write Response:

The Write Response will be sent in response to a Write Request. Some examples:

Request Message	Description
%0101W0931<CR>	A serial transmission error has occurred: Parity error. Write failed.
%0101w100K2<CR>	RAM copy of setpoint #1 modified successfully.

18C/19C/25C Parameter Codes

“X”s mark parameters that are supported by the 18C, 19C, and 25C and “O”s indicate parameters that are not supported.

Table 1. Communications Parameter List (Athena+ Protocol)

Number	Name	Read	Write	Data Field Value
1	Controller Type	X	0	3
2	Software Version	X	0	
3	Communications Version	X	0	
4	Status Byte	X	0	This field contains the ASCII representation of an 8-bit value in which the bit assignments are as follows (starting from the least significant bit):
				X Process Input Error
				X RAS Error
				0 Always Zero
				X Loop Break
				X Alarm 1 Active
				X Alarm 2 Active
				0 Always Zero
				0 Always Zero

If a bit at a location marked as “X” is set, then the condition is TRUE. For example, a “48.000” in the data field means that both alarm 1 and alarm 2 are active and everything else is FALSE.

Series 18C/19C/25C Temperature/Process Controller

Table 1. Communications Parameter List (Athena+ Protocol) Continued

Number	Name	Read	Write	Data Field Value
5	Process Value	X	0	
6	Operating Mode	X	X	1 - Manual 2 - Standby 3 - Normal (automatic) 4 - Initiate Autotune 5 - Recipe Run 6 - Recipe Hold
7	Access Level	X	X	1 - Lockout 2 - Setpoint 3 - Setpoint Plus 4 - User 5 - Configuration 6 - Factory
8	Contact/Digital Input State	X	0	0 - Switch Open 1 - Switch Closed
9	Setpoint, RAM, EEPROM	X	X	
10	Setpoint, RAM Only	X	X	
11	Second Setpoint, RAM, EEPROM	X	X	
12	Second Setpoint, RAM only	X	X	
13	Remote Analog Setpoint	X	0	
14	Recipe Setpoint	X	0	
16	Output 1 Percentage	X	0	
17	Output 2 Percentage	X	0	

Series 18C/19C/25C Temperature/Process Controller

Table 1. Communications Parameter List (Athena+ Protocol) Continued

Number	Name	Read	Write	Data Field Value
18	Manual Control Output 1 Percentage	X	X	
19	Manual Control Output 2 Percentage	X	X	
20	Output 1 Deadband	X	X	
21	Output 1 Hysteresis	X	X	
22	Output 1 Proportional Band	X	X	
23	Output 2 Proportional Band	X	X	
30	Rate (Derivative) Value	X	X	
32	Reset (Integral) Value	X	X	
34	Manual Reset (Integral) Value	X	X	
37	Output 2 Deadband	X	X	
38	Output 2 Hysteresis	X	X	
39	Autotune Damping	X	X	1 - Low 2 - Normal 3 - High
40	Recipe Option	X X X	X X X	0 - Disabled 1 - Single Step 2 - Multi-Step
41	Single-Setpoint Ramp Time	X	X	

Series 18C/19C/25C Temperature/Process Controller

Table 1. Communications Parameter List (Athena+ Protocol) Continued

Number	Name	Read	Write	Data Field Value
42-49	Ramp Times 1-8	X	X	
50-57	Ramp Events 1-8	X	X	0 - Disabled 1 - Event 1 On 2 - Event 1 Off 3 - Event 2 On 4 - Event 2 Off
58-65	Soak Levels 1-8	X	X	
66-73	Soak Times 1-8	X	X	
74-81	Soak Events 1-8	X	X	0 - Disabled 1 - Event 1 On 2 - Event 1 Off 3 - Event 2 On 4 - Event 2 Off
82	Recycle Number	X	X	
83	Holdback Band	X	X	
84	Termination State	X	X	0 - Last Setpoint 1 - Default Setpoint 2 - Recipe to Standby Mode
85	Power Fail Resume Enable	X	X	1 - Resume Off 2 - Resume On
86	Input Bias	X	X	
87	Input Low Scale	X	X	
88	Input High Scale	X	X	
89	Lower Setpoint Limit	X	X	

Table 1. Communications Parameter List (Athena+ Protocol) Continued

Number	Name	Read	Write	Data Field Value
90	Upper Setpoint Limit	X	X	
91	Input Filter	X	X	
92	Input Type	X	X	0 - B Thermocouple 1 - C Thermocouple 2 - E Thermocouple 3 - J Thermocouple 4 - K Thermocouple 5 - N Thermocouple 6 - NNM Thermocouple 7 - R Thermocouple 8 - S Thermocouple 9 - T Thermocouple 10 - Platinel® II Thermocouple 11 - RTD (Integer) 12 - RTD (Decimal) 13 - 0-20 mA 14 - 4-20 mA 15 - 0-10 mV 16 - 0-50 mV 17 - 0-100 mV 18 - 10-50 mV 19 - 0-1 V 20 - 0-5 V 21 - 0-10 V 22 - 1-5 V

Series 18C/19C/25C Temperature/Process Controller

Table 1. Communications Parameter List (Athena+ Protocol) Continued

Number	Name	Read	Write	Data Field Value
94	Output 1 Type	X	X	1 - Inactive/Disabled 2 - PID 4 - On/Off
95	Output 1 Action	X	X	1 - Direct 2 - Reverse
A2	Output 1 Cycle Time	X	X	
A3	Output 1 Low Limit	X	X	
A4	Output 1 High Limit	X	X	
A5	Output 2 Type	X	X	1 - Inactive/Disabled 2 - PID 4 - On/Off
A6	Output 2 Action	X	X	1 - Direct 2 - Reverse
B3	Output 2 Cycle Time	X	X	
B4	Output 2 Low Limit	X	X	
B5	Output 2 High Limit	X	X	
B6	TC/RTD Decimal Position	X	X	
B7	Linear Decimal Position	X	X	
B8	Display Filter	X	X	
B9	Display Units	X	X	1 - Fahrenheit 2 - Celsius 3 - Kelvin

Table 1. Communications Parameter List (Athena+ Protocol) Continued

Number	Name	Read	Write	Data Field Value
C1	Display Blanking	X	X	
C2	Alarm 1 Action			1 - Off 2 - Normal 3 - Latched 4 - Event
C3	Alarm 1 Operation	X	X	1 - Process High 2 - Process Low 3 - Deviation High 4 - Deviation Low 5 - Normal Band 6 - Inverse Band
C4	Alarm 1 Delay	X	X	
C5	Alarm 1 Inhibit	X	X	
C6	Alarm 1 Process Setpoint	X	X	
C7	Alarm 1 Deviation Setpoint	X	X	
C8	Alarm 2 Action	X	X	1 - Off 2 - Normal 3 - Latched 4 - Event
C9	Alarm 2 Operation	X	X	1 - Process High 2 - Process Low 3 - Deviation High 4 - Deviation Low 5 - Normal Band 6 - Inverse Band

Series 18C/19C/25C Temperature/Process Controller

Table 1. Communications Parameter List (Athena+ Protocol) Continued

Number	Name	Read	Write	Data Field Value
D0	Alarm 2 Delay	X	X	
D1	Alarm 2 Inhibit	X	X	
D2	Alarm 2 Process Setpoint	X	X	
D3	Alarm 2 Deviation Setpoint	X	X	
D4	Communications Protocol	X	0	1 - Athena +
D5	Communications ID	X	X	
D6	Baud Rate	X	X	0 - 75 1 - 150 2 - 300 3 - 600 4 - 1200 5 - 2400 6 - 4800 7 - 9600
D7	Data Format	X	X	0 - 7-0-1 1 - 7-E-1 2 - 7-N-2 3 - 7-0-2 4 - 7-E-2 5 - 8-N-1 6 - 8-0-1 7 - 8-E-1 8 - 8-N-2

Series 18C/19C/25C Temperature/Process Controller

Table 1. Communications Parameter List (Athena+ Protocol) Continued

Number	Name	Read	Write	Data Field Value
D8	Communications Transmit Delay	X	X	
E1	Output 1 Failsafe %	X	X	
E2	Output 2 Failsafe %	X	X	
E3	Loop Break Time	X	X	
E4	Highest Reading	X	X	
E5	Lowest Reading	X	X	
E8	Option Selection	X	0	1 - Comm Option
E9	TC Zero Calibration	X	X	
F0	TC Span Calibration	X	X	
F1	RTD Zero Calibration	X	X	
F2	RTD Span Calibration	X	X	
F3	Low-Voltage Zero Calibration	X	X	
F4	Low-Voltage Span Calibration	X	X	
F5	High-Voltage Zero Calibration	X	X	
F6	High-Voltage Span Calibration	X	X	
F7	Current Zero Calibration	X	X	
F8	Current Span Calibration	X	X	
G1	Auxiliary Output Variable	X	X	
G2	Auxiliary Output Scale Low	X	X	
G3	Auxiliary Output Scale High	X	X	
G5	RAS Scale Low	X	X	
G6	RAS Scale High	X	X	
G7	Contact/ Digital Switch	X	X	1 - Disabled 2 - Second Setpoint Select 3 - Standby Select 4 - Run/Hold Switch

Table 1. Communications Parameter List (Athena+ Protocol) Continued

Number	Name	Read	Write	Data Field Value
H2	Autotune State	X	0	0 - Success 1 - Aborted 2 - Error: No PID Output 3 - Error: No Deviation 4 - Error: No Output 5 - Error: Timed out 6 - Error: Bad Tune 7 - Waiting for PV to settle 8 - Reverse Tune In Progress 9 - Direct Tune In Progress
H3	Recipe State	X	0	
H5	Current Recipe Statement	X	0	
H6	Active Setpoint	X	X	
H7	Resume Exhaustion Flag	X	0	
H8	LED Status Indicator		X	0
H9	RTD Decimal Zero Calibration		X	X
I0	RTD Decimal Span Calibration		X	X
I1	1-5 V, 0-10 V Zero Calibration		X	X
I2	1-5 V, 0-10 V Span Calibration		X	X
I3	10-050 mV, 0-100 mV Zero Calibration		X	X
I4	10-50 mV, 0-100 mV Span Calibration		X	X

Auxiliary Commands:

Command: **Load Parameter Defaults**

Parameter #: 01

Description: Restore all menu parameters to their default values.

Request

Data Field: Ignored.

Response

Data Field: Ignored.

Command: **Perform Process Low Calibration**

Parameter #: 02

Description: Performs a Low Calibration. The data field in the request message specifies the process. Make sure the prerequisite for the calibration is satisfied before issuing a calibration command. For instance, the RTD calibration command must only be used when the input sensor type is chosen as RTD or RTD w/ Decimal.

Request

Data Fields: A 10 character ASCII representation of a numeric value specifying what to calibrate.

- 0 - Thermocouple
- 1 - RTD, Resistive Thermal Device
- 2 - Linear
- 3 - RAS, Remote Analog Setpoint

Response

Data Field: Ignored.

Command: **Perform Process High Calibration**

Parameter #: 03

Description: Performs a High Calibration. The data field in the request message specifies the process.

Make sure the prerequisite for the calibration is satisfied before issuing a calibration command. For instance, the RTD calibration command must only be used when the input sensor type is chosen as RTD or RTD w/ Decimal.

Request
Data Field:

A 10 character ASCII representation of a numeric value specifying what to calibrate.
0 - Thermocouple
1 - RTD, Resistive Thermal Device
2 - Linear
3 - RAS, Remote Analog Setpoint

Command: **Retrieve Display**

Parameter #: 05

Description: Retrieves the string currently displayed on the slave's display. The data field in the request message specifies which display and the data field in the response message contains the string.

Request
Data Field:

A 10 character ASCII representation of a numeric value specifying which display to retrieve data from.
0 - Lower Display
1 - Upper Display

Response
Data Field:

The ASCII string.

Command: **Clear Latched Alarms**

Parameter #: 10

Description: Clear all latched alarms.

Request

Data Field: Ignored.

Response

Data Field: Ignored.

**For Technical Assistance in the U.S.,
Call Toll Free: 800.782.6776**



CORPORATE HEADQUARTERS

Athena Controls, Inc.
5145 Campus Drive
Plymouth Meeting, PA 19462 U.S.A.
Tel: 610.828.2490
Fax: 610.828.7084
Toll-Free in U.S.: 800.782.6776
Internet: www.athenacontrols.com