



# SERIES 80

TEMPERATURE  
CONTROLLERS

## Instruction Manual



Note: Not all agency approvals apply to all models. See manual for detailed information.



# Series 80 Agency Approvals



LR-52383  
Models 82 and 86



E63164 Process Control Equipment, Component  
UL-1092 / UL-916, C22.2 No. M142-1987  
Models 82-A, 82-B, 86-A & 86-B (Vol.1, Sec.1)  
Models 88-A, 88-B, 88-L, 89-1 & 89-2 (Vol.1, Sec. 2)



E63164 Process Control Equipment  
UL-1092 / UL-916, C22.2 No. M142-1987  
Models 82-C, 82-D, 82-E, 82-L, 86-C, 86-D, 86-E & 86-L (Vol.2, Sec.2)



ID. 3012472 Class 3545, Temperature Limit Controllers  
Models 86-L & 88-L

Athena Controls, Inc.  
5145 Campus Drive  
Plymouth Meeting, PA 19462  
Phone: 610-828-2490  
Fax: 610-828-7084  
[www.athenacontrols.com](http://www.athenacontrols.com)

You can reach our technical support team by phoning 1-800-782-6776 (from the United States) or 610-828-2490 (from anywhere in the world). The e-mail address for tech support is [techsupport@athenacontrols.com](mailto:techsupport@athenacontrols.com)

Athena® is a registered trademark of Athena Controls, Inc.

© 2004 Athena Controls, Inc. All rights reserved.

# Table of Contents

<b>Section 1</b>	<b>General Introduction</b>	
1.1	General Description and Cautions.....	1
1.2	Configurations.....	1
1.3	Specifications.....	2
<b>Section 2</b>	<b>Preliminary Instructions</b>	
2.1	Unpacking.....	3
2.2	Locating.....	3
2.3	Mounting.....	3
2.4	Wiring.....	3
2.5	Thermocouple Placement.....	5
<b>Section 3</b>	<b>Operation / Maintenance</b>	
3.1	Operation.....	5
3.2	Limit Control.....	5
3.3	Adjustments.....	5
3.4	Maintenance.....	6
<b>Section 4</b>	<b>Troubleshooting</b>	
4.1	Troubleshooting Steps.....	7

# Section 1      General Introduction

## 1.1      General Description and Cautions

The Athena Series 80 Controllers are designed for temperature control of ovens, molds, hot stamping machines, packaging machinery, heat tracing, and for replacement of bulb and capillary type temperature controllers. Limit configurations have FM approval.

### CAUTION

*Possible fire hazard. Because these temperature controls or associated equipment may not always fail safe, an approved temperature and/or pressure safety control should be used for safe operation.*

## 1.2      Configurations

- A - Open PCB unit with Setpoint on the PCB
- B - Open PCB unit with Remote Setpoint
- C - Open PCB unit with Setpoint on PCB with T case
- D - T case with Setpoint on the case
- E - T case with Remote Setpoint
- L - High Limit Controller, D configuration with Reset button on case

## 1.3 Specifications

<b>Setpoint:</b>	Single turn, 270° rotation Potentiometer (local or remote)
<b>Setpoint Resolution:</b>	1% with circuit board Potentiometer ¼% with remote Potentiometer
<b>Calibration Accuracy:</b>	1% at calibration points with remote Potentiometer 2% at calibration points Potentiometer on circuit board
<b>Ambient Temperature Range:</b>	30° to 130° F Series 82 & 86 30° to 150° F Series 88
<b>Cold Junction Compensation:</b>	Internal electrical bridge
<b>Differential/Proportional Band:</b>	Adjustable from Differential of 5° F to Proportional Band of 25° F
<b>Thermocouple Break Protection:</b>	UPSCALE
<b>Output:</b>	B – S.P.S.T. relay 10A/5A H – S.P.S.T. relay 15A S – Pulsed D.C. 0-20Vdc T – Solid State relay 1Aac, 1Ø (Normally Open)
<b>Supply Voltage:</b>	120/240 ± 10% V 50/60 Hz.
<b>Power Consumption:</b>	2 watts
<b>Weight:</b>	1 pound, 8 oz. (0.68 kg) with case and cover

## Section 2 Preliminary Instructions

### 2.1 Unpacking

Carefully unpack the instrument and inspect for shipping damage. Report any damage to the carrier immediately.

### 2.2 Locating

Select a location for the controller where it will not be subjected to excessive shock, vibration, dirt, moisture, and/or oil. The ambient temperature of the area should be between 30° F and 130° F (Series 82 & 86), 30° F and 150° F (Series 88).

### 2.3 Mounting (Series 82, 86, 88)

**Panel Mounting, External Setpoint:** Open-faced circuit board with or without mounting snap-track, should be mounted in a suitable approved enclosure to maintain Agency Approvals.

1. Remove knob with small screwdriver and take off the nut holding the scale to the potentiometer.
2. Mount potentiometer through a  $\frac{3}{8}$ " hole in your panel; put scale over shaft and tighten nut.
3. Turn shaft counterclockwise until it stops.
4. Now put knob back on and line up its indicating mark with the arrow on scale.
5. Tighten knob. The unit is now aligned.

#### **Metal Mounting Case:**

1. Remove the two screws holding the cover. Remove the cover.
2. Carefully spread the plastic holding track and remove the circuit board.
3. Mount the base and plastic track with the appropriate hardware (not supplied) through the two  $\frac{1}{8}$ " dia. mounting holes.
4. Replace circuit board by aligning one side in track and then gently press in the opposite side. Replace the cover and cover screws after wiring.

### 2.4 Wiring

Consult the wiring diagrams on page 4. The unit can be operated with 120/240V 50/60 Hz line voltage. Be certain that the correct voltage is applied to the proper terminals. Cooling loads can be driven from the Normally Closed terminal. There is no fusing on the circuit board, therefore to prevent damage to the control

# Series 86/88 Wiring & Mounting

## 120 Volt Units

Height = 1 1/16"

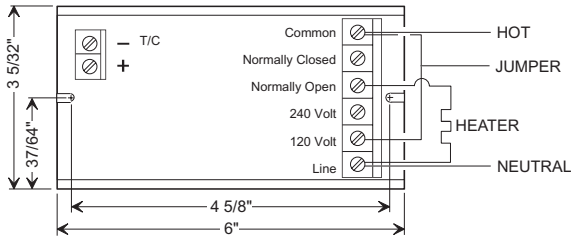

# Series 86/88 Wiring & Mounting

## 240 Volt Units

Height = 1 1/16"

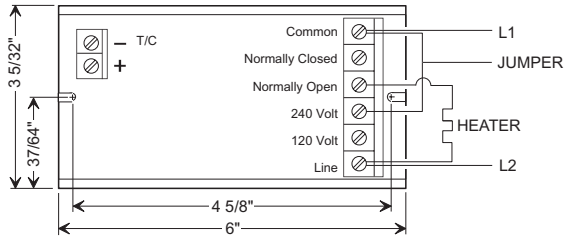

- Notes:
1. Model 86 is shown. Model 88 uses push-on connectors instead of terminal blocks.
  2. For cooling application use Normally Closed in place of Normally Open.
  3. Models 82 and 83 have different terminal location than models 86 and 88.

### Series 86 only:

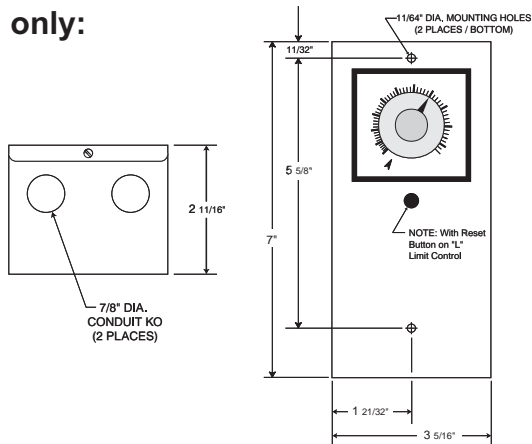

circuitry and load relay, the customer must provide adequate fusing. Separate fusing for the control circuitry and load relay is preferred, however a single fuse is acceptable. Proper segregation must be provided between the Class 2 thermocouple /RTD input, potentiometer and the Class 1 circuits. Wiring should be in compliance with local and National Electrical Codes.

## **2.5 Thermocouple Placement**

Proper thermocouple placement can eliminate many problems in the system. The probe should be placed so that it can detect any temperature change with little thermal lag. In a process that requires fairly constant heat output, the probe should be placed close to the heater. In processes where heat demand is variable, the probe should be close to the work area. Some experimenting with probe location will provide optimum results. Thermocouple extension wire must be of sufficient size so that on long runs the thermocouple circuit resistance does not exceed 100 ohms.

# **Section 3 Operation / Maintenance**

## **3.1 Operation**

After all connections are completed, adjust the Setpoint Knob to the desired temperature and apply line voltage. Adjust the Band Potentiometer as per section 3.3. If Proportional operation has been selected, the output will cycle on and off continuously. If On-Off mode has been selected, the output will change state only as temperature varies around the setpoint.

## **3.2 Limit Control**

Adjust the Setpoint Knob to the desired limit temperature. Apply power and press the Manual Reset Button. The Control Relay is now energized, the normally open and common contacts closed. When the process temperature being monitored by the limit thermocouple reaches the set value, the limit relay will change state and latch in that state until the monitored temperature falls below the setpoint and the Manual Reset Button is depressed. An option is available to provide automatic reset of the limit upon application of control power.

## **3.3 Adjustments**

The Band adjustment allows the control mode to be Proportional to On-Off.

For processes requiring very accurate control, adjust the MODE Potentiometer clockwise in the Proportional sector until the process temperature oscillations just stop.

For processes requiring very accurate control, adjust the MODE Potentiometer clockwise in the Proportional sector until the process temperature oscillations just stop.

For processes such as mechanical refrigeration systems, fans, solenoid valves, and wherever continuous cycling would be detrimental to the load handler, On-Off control should be used. Adjusting the Band Potentiometer counterclockwise from its center of travel provides On-Off control. The amount of hysteresis (differential) is increased with further counterclockwise adjustments of the Band Potentiometer. Adjustment here provides a compromise between tight temperature control and minimum cycling of the load handler.

SERIES 80  
USER ADJUSTMENTS

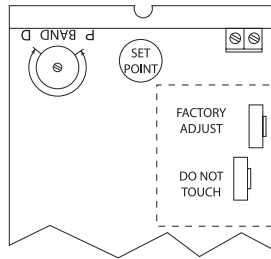

Adjusting the Band Potentiometer counterclockwise from its center of travel provides On-Off control. The amount of hysteresis (differential) is increased with further counterclockwise adjustments of the Band Potentiometer. Adjustment here provides a compromise between tight temperature control and minimum cycling of the load handler.

**Band Adjustments**

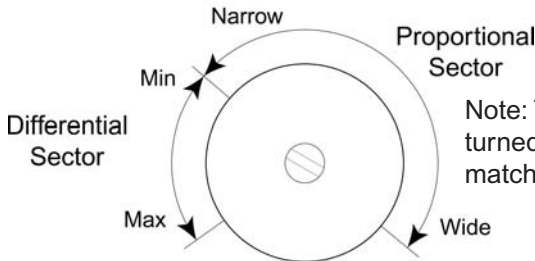

Note: The unit needs to be turned upside-down to match graphic.

**3.4 Maintenance**

1. Keep the controller clean and protect it from dirt, water, and corrosive fumes.
2. Periodically recheck electrical connections
3. If relay problems are seen, return for repair.

**WARNING**

*Applying incorrect voltage will damage controller.  
Shorted heaters or wires can damage the relay.  
For maximum protection, fuse incoming power lines with a quick-acting fuse.*

---

## Section 4      Troubleshooting

Prior to checking controller operation, insure system peripherals are functional as follows:

- Wiring: Circuit correctly wired
- Thermocouple: Correct type, continuity ok
- Line voltage: Within specification
- Load handler: Functional

Note: When lit, the LED display only indicates output activation.

### 4.1 Troubleshooting Steps

1. Connect simulated sensor input, as follows:  
    Millivolt input: thermocouple units  
    Resistance bridge: RTD units
2. Disconnect AC wiring (except for "T" output) from load terminal before connecting output measurement device:  
    "B" output              Ohmmeter  
    "T" output AC Voltmeter. Controller output connected to load device and power supply (see pg 4).  
    "S" output              DC Voltmeter  
    "F" output DC Milliammeter
3. Adjust the MODE Potentiometer fully counterclockwise.
4. Connect and apply line voltage.
5. Adjust setpoint to mid-range.
6. Adjust the simulated sensor input to below setpoint and observe output on; calling for heat.
7. Adjust the simulated sensor input to above setpoint and observe output off; not calling for heat.
8. If no output state change in steps 6 & 7, possible:  
    Defective output device  
    Defective controller electronics
9. Call Athena Controls technical support 1-800-782-6776 for assistance and, if needed, return instructions.
10. Return controller to an authorized service center for electronics repairs.

## **Two-Year Limited Warranty**

THIS EQUIPMENT IS WARRANTED TO BE FREE FROM DEFECTS OF MATERIAL AND WORKMANSHIP. IT IS SOLD SUBJECT TO OUR MUTUAL AGREEMENT THAT THE LIABILITY OF ATHENA CONTROLS, INCORPORATED IS TO REPLACE OR REPAIR THIS EQUIPMENT AT ITS FACTORY, PROVIDED THAT IT IS RETURNED WITH TRANSPORTATION PREPAID WITHIN TWO (2) YEARS OF ITS PURCHASE.

THE PURCHASER AGREES THAT ATHENA CONTROLS, INCORPORATED ASSUMES NO LIABILITY UNDER ANY CIRCUMSTANCES FOR CONSEQUENTIAL DAMAGES RESULTING FROM ITS USE OR FROM IMPROPER HANDLING OR PACKAGING OF SHIPMENTS RETURNED TO THE FACTORY.

COMPONENTS WHICH WEAR OR WHICH ARE DAMAGED BY MISUSE ARE NOT WARRANTED. THESE INCLUDE CONTACT POINTS, FUSES, ELECTROMECHANICAL RELAYS, AND TRIACS. UNITS WHICH HAVE BEEN MODIFIED BY A CUSTOMER IN ANY WAY ARE NOT WARRANTED.

Other than those expressly stated herein, THERE ARE NO OTHER WARRANTIES OF ANY KIND, EXPRESS OR IMPLIED, AND SPECIFICALLY EXCLUDED BUT NOT BY WAY OF LIMITATION, ARE THE IMPLIED WARRANTIES OF FITNESS FOR A PARTICULAR PURPOSE AND MERCHANTABILITY.

IT IS UNDERSTOOD AND AGREED THE SELLER'S LIABILITY WHETHER IN CONTRACT, IN TORT, UNDER ANY WARRANTY, IN NEGLIGENCE OR OTHERWISE SHALL NOT EXCEED THE RETURN OF THE AMOUNT OF THE PURCHASE PRICE PAID BY THE PURCHASER AND UNDER NO CIRCUMSTANCES SHALL SELLER BE LIABLE FOR SPECIAL, INDIRECT, INCIDENTAL OR CONSEQUENTIAL DAMAGES. THE PRICE STATED FOR THE EQUIPMENT IS A CONSIDERATION IN LIMITING SELLER'S LIABILITY. NO ACTION, REGARDLESS OF FORM, ARISING OUT OF THE TRANSACTIONS OF THIS AGREEMENT MAY BE BROUGHT BY PURCHASER MORE THAN ONE YEAR AFTER THE CAUSE OF ACTION HAS ACCRUED.

SELLER'S MAXIMUM LIABILITY SHALL NOT EXCEED AND BUYER'S REMEDY IS LIMITED TO EITHER (i) REPAIR OR REPLACEMENT OF THE DEFECTIVE PART OR PRODUCT, OR AT SELLER'S OPTION (ii) RETURN OF THE PRODUCT AND REFUND OF THE PURCHASE PRICE, AND SUCH REMEDY SHALL BE BUYER'S ENTIRE AND EXCLUSIVE REMEDY. THE SPECIFICATIONS PUT FORTH IN THIS MANUAL ARE SUBJECT TO CHANGE WITHOUT NOTICE.

## **Authorized Athena Service Centers**

Athena Controls, Inc.  
5145 Campus Drive  
Plymouth Meeting, PA 19462  
610-828-2490

Athena Controls, Inc.  
1640 E. Acorn Lane  
Glendora, CA 91740  
818-963-5045

Allied Instrument Service  
3136 Clarence Avenue  
Berwyn, IL 60402  
708-788-1912

***For free technical assistance in the U.S.,  
call toll free 1-800-782-6776 or  
email [techsupport@athenacontrols.com](mailto:techsupport@athenacontrols.com)***



Athena Controls, Inc • 5145 Campus Drive • Plymouth Meeting, PA 19462 USA  
Tel: 610-828-2490 • Fax: 610-828-7084 • [techsupport@athenacontrols.com](mailto:techsupport@athenacontrols.com) • [athenacontrols.com](http://athenacontrols.com)