

BASE METAL THERMOCOUPLE ASSEMBLIES

These metal protection tube assemblies are offered in a wide variety of aluminum connection heads and mounting options. Specifications and part numbers are detailed in the tables below, permitting the greatest flexibility in selecting the exact design required. Assemblies are shipped pre-tested and ready to install.

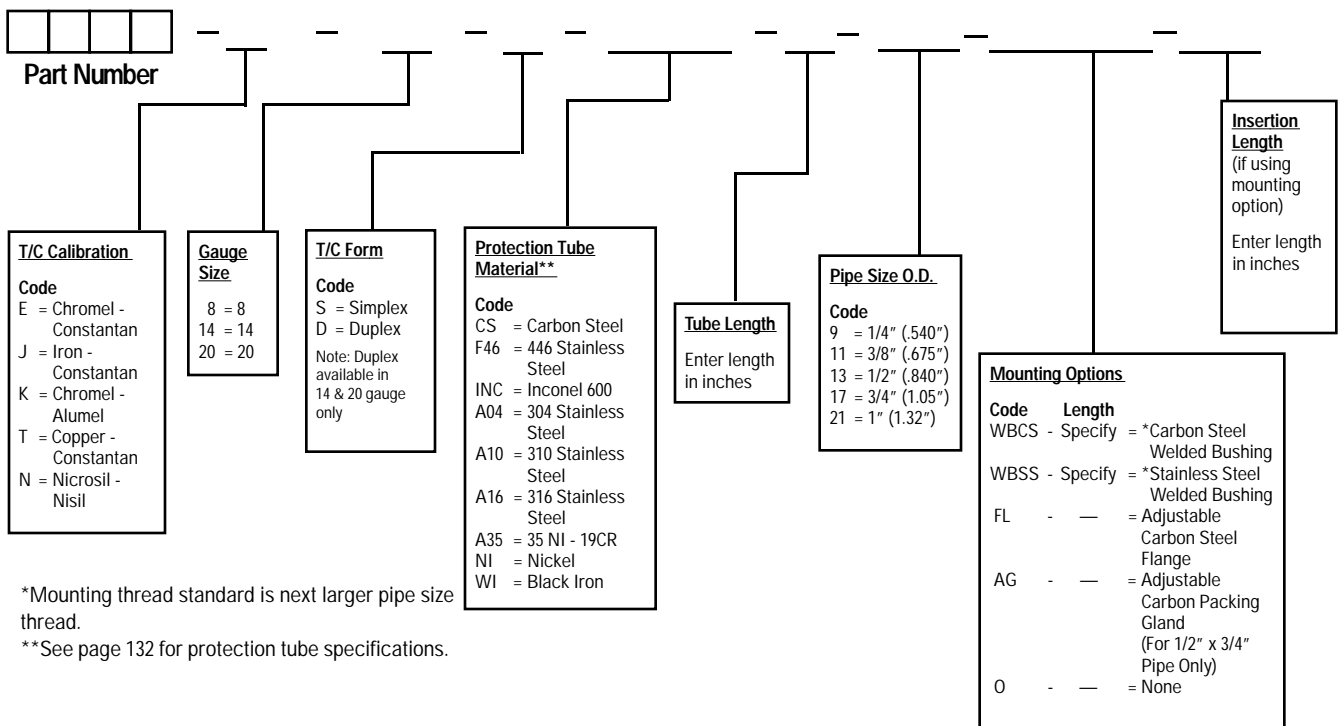

Ordering Information



BASE METAL THERMOCOUPLE ASSEMBLIES

STRAIGHT – METAL PROTECTION TUBE ASSEMBLIES

Part No.	Style
9034	Schedule 40 pipe with General Purpose connection head.
9036	Schedule 80 pipe with General Purpose connection head.
9035	Schedule 40 pipe with weatherproof Heavy Duty connection head.
9037	Schedule 80 pipe with weatherproof Heavy Duty connection head.

STRAIGHT ASSEMBLIES WITH OPTIONS

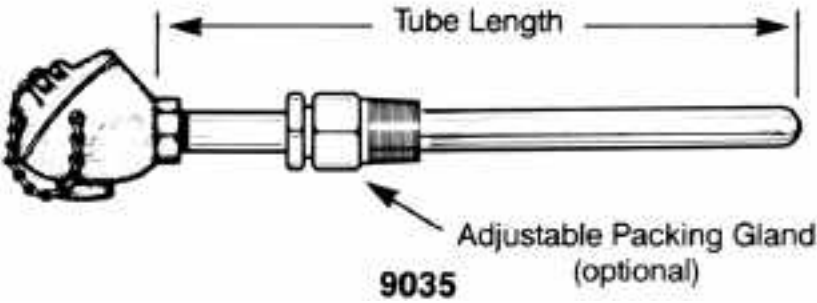
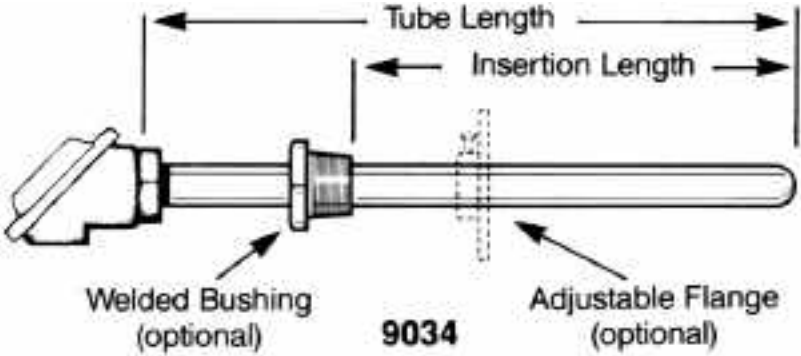

Tudor™
 Temperature
 Sensors

BASE METAL THERMOCOUPLE ASSEMBLIES

ANGLE – METAL PROTECTION TUBE ASSEMBLIES

Part No.	Style
9030	Schedule 40 H.L. pipe with General Purpose connection head.
9032	Schedule 80 H.L. pipe with General Purpose connection head.
9130	Silicone carbide H.L. with General Purpose connection head.
9033	Schedule 80 H.L. pipe with Heavy Duty connection head.
9131	Silicone carbide H.L. with Heavy Duty connection head.

ANGLE ASSEMBLIES

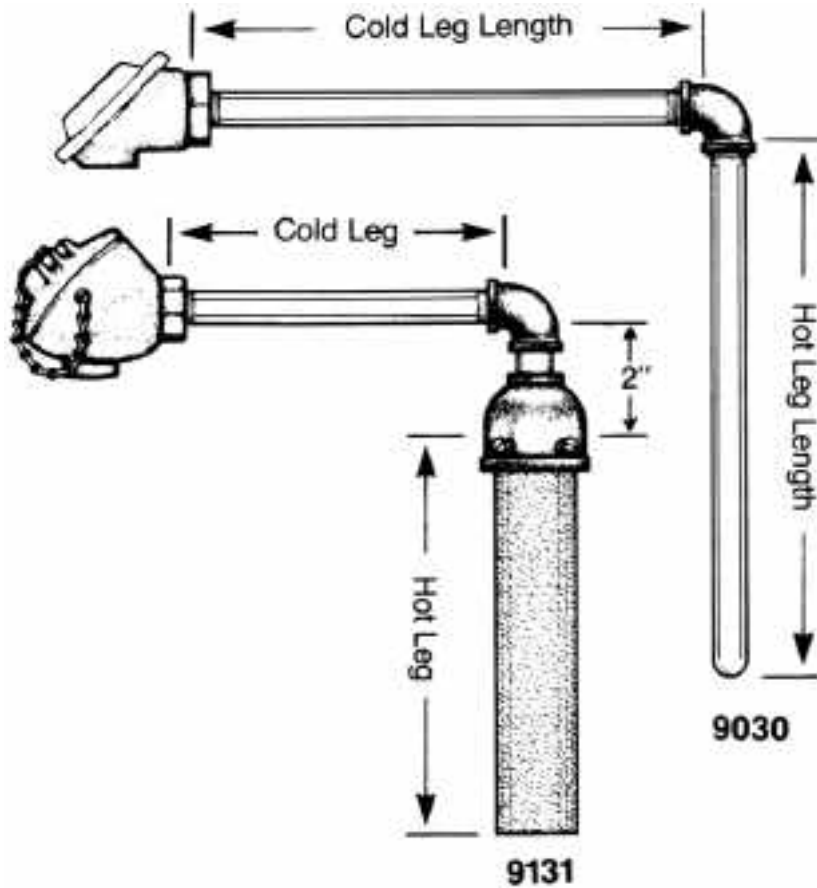

BASE METAL THERMOCOUPLE ASSEMBLIES



Ordering Information

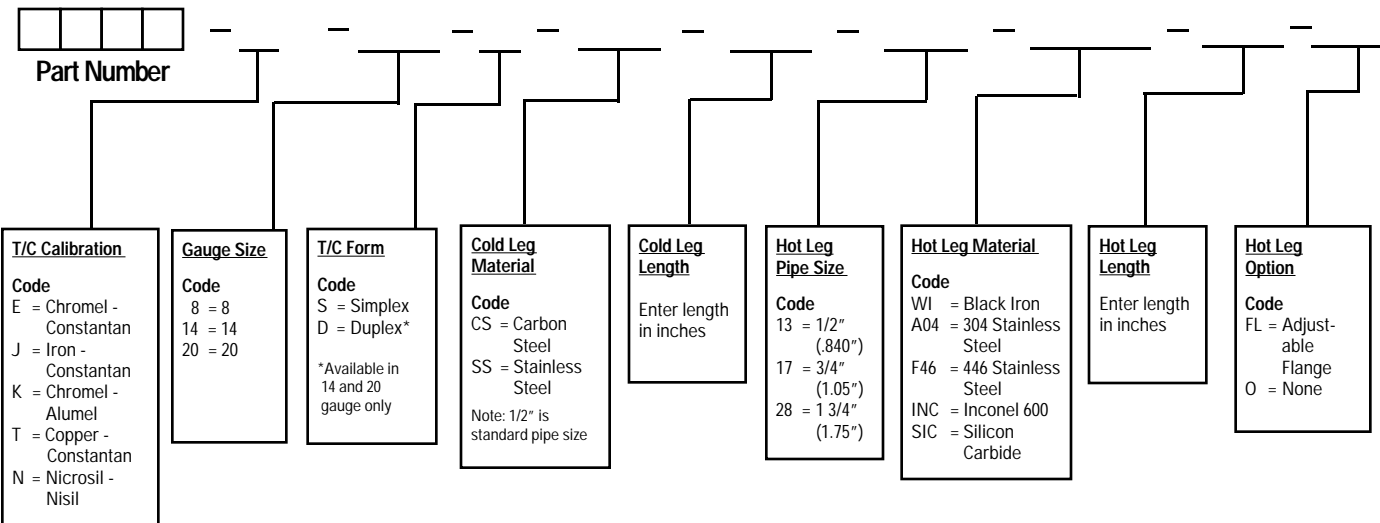

Tudor™
Temperature
Sensors