

CERAMIC TUBE THERMOCOUPLE ASSEMBLIES

Ceramic protection tube assemblies are offered in a wide variety of aluminum connection heads and mounting options. Specifications and part numbers are detailed in the tables below to permit excellent flexibility in selecting the exact design required. Assemblies are shipped pre-tested and ready to install.

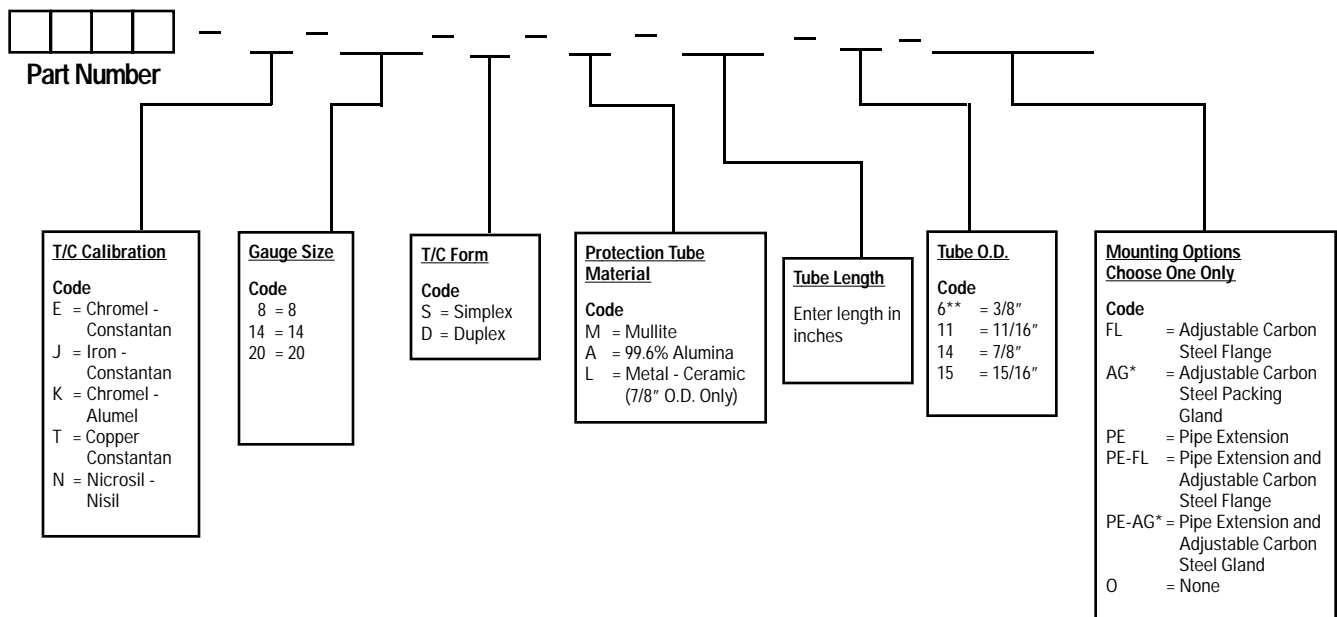

Ordering Information



*Gland shown on assembly 9035, page 96. Minimum pipe extension length is four inches.

**Maximum wire size is 20 gauge.

CERAMIC TUBE THERMOCOUPLE ASSEMBLIES

STRAIGHT – CERAMIC PROTECTION TUBE ASSEMBLIES

Part No.	Style
9075	General Purpose connection head.
9076	Heavy Duty Screw Cover connection head.
9077	Light Weight Screw Cover connection head.

CERAMIC TUBE ASSEMBLIES

